

Content

A. General Introduction	1
B. Application	1
C. Features	1
D. Safety Instructions	1
E. Front View Main Functions	2
F. Rear View Main Functions	3
G. Pre-Installation Information	3
H. Electrical Requirements	3
I. Installation Requirements	4
J. Connection And Testing	5
K. Operation	6
L. Green Power Adjustment	7
M. Trouble Shooting	7
N. Maintenance	9
O. Specifications	9

A. General Introduction

We are experts in DC to AC Power Inverter and Solar Inverter. Our engineers are making use of advanced technological design that results in an inverter that is more excellent, smarter and easier to use than any other inverter with similar power ratings. We have been developed to provide you with years of trouble free operation. We provide a Pure Sine Wave output with very high quality power, often with less spikes and surges than grid-supplied power.

Please take a few minutes to read this manual carefully.

B. Application:

Pure Sine Wave Power Inverters provide 150, 350, 650, 1000, 1200 , 1800 and 3000 watts of Pure Sine Wave AC power from a DC source.

C. Features:

Capable of driving inductive loads, i.e., electric tools and appliances	Microprocessor-based design with accurate and stable frequency
Does not affect other equipment like TV, radio...etc	Standard outputs adjustable 100~120V, 200~240V, 50/60Hz
Standard specially-designed AC and DC line filters	Panel indicators for battery voltage & load level (%)
Specific chassis for harsh environments	Standard inputs 12V, 24V (48V Custom design)
No problem with microwave ovens	Very low harmonic distortion, THD<3%
Standard low battery cut-off	Quick response, standby functions
Great overload performance	RS232 interface (option)
State-of-Art auto load sense	Very efficient stand-by circuit
Pure sine wave at 50~60Hz	Can be used anywhere
Lowest installation cost	Simplified system design
Extremely efficient	Remote control unit
Easily mounted	Green Power
No noise	Reliable

D. Safety Instructions:



WARNING!

Before installing and using your inverter, read the Safety Instructions!

1. General Safety Precautions:

- Do not expose the Inverter to rain, snow, spray, bilge or dust.
- To reduce risk of hazard, do not cover or obstruct the ventilation openings.
- Do not install the Inverter in a zero-clearance compartment. Overheating may result.
- To avoid a risk of fire and electronic shock, make sure that existing wiring is in good electrical condition and that wire is not undersized.
- Do not operate the Inverter with damaged or substandard wiring.

2. Explosive Gas Precautions:

This equipment contains components that can produce arcs or sparks. To prevent fire or explosion do not install in compartments containing batteries or flammable materials, or in locations that require ignition-protected equipment. This includes any space containing gasoline-powered machinery, fuel tanks, or joints, fittings, or other connections between components of the fuel system.

3. Precautions When Working With Batteries

If battery acid contacts skin or clothing, wash immediately with soap and water. If acid gets into eyes, immediately flood eyes with running cold water for at least 20 minutes and get medical attention immediately.

- **NEVER** smoke or allow a spark or flame in vicinity of batteries or engine. Do not drop a metal tool on the battery. The resulting spark or short-circuit of the battery may cause an explosion.
- **Remove personal metal items such as rings, bracelets, necklaces, and watches when working with a lead-acid battery. A lead-acid battery produces a short-circuit current high enough to weld a ring or similar metal, causing a severe burn.**

4. Installation and Operation:

To get the most out of the power inverter, it must be installed and used properly.

E. Front View & Main Functions:

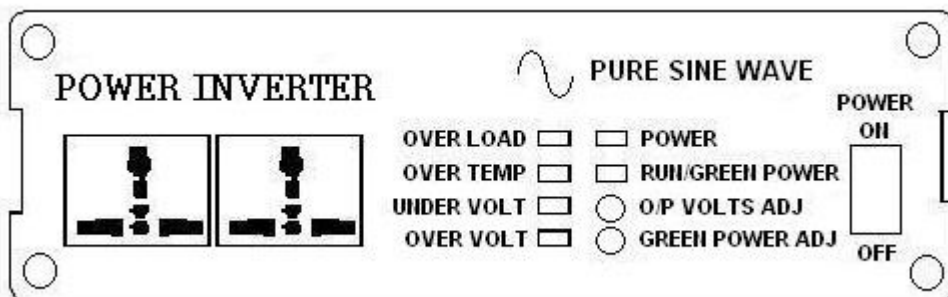

1. ON / OFF switch:

Power ON/OFF switch, leave in the OFF position during installation.

2. LED INDICATION:

Over Volt: Over Voltage Protection. **Over Temp:** Over Temperature Protection.

Under Volt: Under Voltage Protection. **Over Load:** Over Load Protection.

Power: Power ON. **Run/Green Power:** Indicates current operating condition of the inverter.

3. AC outlet (Outlet sockets available)

- North America (GFCI)
- North America
- Continental European (Schuko)
- Australia / New Zealand
- United Kingdom
- Universal Socket

F. Rear View & Main Functions:

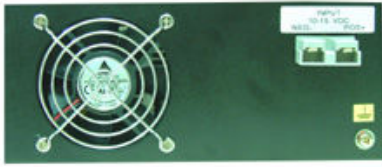

0350L, 0650L

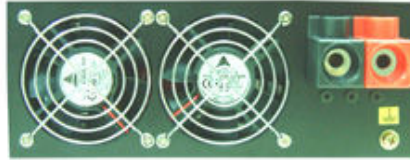

1200L



1800L



3000L

1. Ventilation window:

Do not obstruct; allow at least 1 inch for airflow.

2. Battery terminals:

Connect to 12V / 24V / 48V battery or other 12V / 24V / 48V power source. (+) is positive, (-) is negative. **WARNING!** Reverse polarity connection will blow internal fuse and may damage inverter permanently.

3. RS-232C (located on the side of the inverter):

Connect to remote control unit (option accessory) or remote-control by computer.



WARNING! Shock Hazard!



Before proceeding Further, ensure that the Inverter is NOT connected to any Batteries, and that all wiring is Disconnected from any electrical Sources. Do not connect the output Terminals of the Inverter to an incoming AC sources.

G. Pre-Installation Information:

Before installing your inverter, please make sure that you have appropriately- sized batteries. A battery that is too small will not allow the inverter to perform to its full specification.

H. Electrical Requirements

DC input voltage of the inverter must be the same as the battery bank voltage.

DC cabling must be connected to the correct polarity terminals of the battery bank (Red = Positive, Black = Negative).

DO NOT extend the DC cable length to the inverter unless you are prepared to increase the diameter of the cable. If this is necessary consult your supplier / installer for advice.

DO NOT connect AC power to the output of the inverter: **THIS WILL DAMAGE THE INVERTER.** Between the inverter and any generator / mains supply, install a double-pole “break-before-make” changeover switch, switching both line and neutral.

I. Installation Requirements:

- 1. Where to install**—The power inverter should be installed in a location that meets the following requirements:
 - **Dry**— Do not allow water to drip or splash on the inverter, free of salt or moisture-laden air.
 - **Temperature** – Ambient air temperature should be between 0°C and 40°C.
 - **Safety**—Do not install in a battery compartment or other areas where flammable fumes may exist, such as fuel storage or engine compartments.
 - **Ventilation**—Allow at least one inch of clearance around the inverter for airflow. Ensure the ventilation openings on the rear and bottom of the unit are not obstructed. The installation site should not be susceptible to temperatures in excess of 50°C.
 - **Dust-free**—Do not install the inverter in an environment where either dust, wood particles or other filings/shavings are present. These can pull into the unit blocking the cooling fan.
 - **Close to battery/batteries**—Avoid excessive cable lengths (*Mount the inverter between one and two meters from the batteries*) but do not install the inverter over or in the same compartment as batteries. Use the recommended wire lengths and sizes. Do not mount the inverter where it will be exposed to the gases produced by the battery. These gases are very corrosive and prolonged exposure will damage the inverter.
 - **Wall-mount**—Inspection and operation are more convenient if the unit is mounted at head height and the DC cables hang naturally out of the way.
- 2. AC safety Grounding:** The AC input ground wire must connect to the incoming ground from your AC utility source. The AC output ground wire should go to the grounding point for your loads (for example, a distribution panel ground bus).
- 3. Neutral Grounding:**

115V models: The neutral conductor of the AC output circuit of the Inverter is automatically connected to the safety ground during inverter operation. This conforms to National Electrical Code safety requirements. For models configured with a transfer relay, when AC utility power is present and the inverter is in bypass mode, this connection (neutral of the inverter's AC output to input ground) is not present so that the utility neutral is only connected to ground at your breaker panel, as required.

230V models: There is no connection made inside the Inverter from either of the line conductors (line or neutral) to the earth ground.

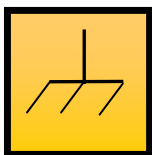

WARNING!

Operation of the inverter without a proper ground connection may result in an electrical safety hazard.

PLEASE READ THESE INSTRUCTIONS CAREFULLY BEFORE COMMENCING INSTALLATION.

Installation should be performed by competent professional electrical/renewable energy installer, as dangerous voltages can be present.

Complete the following steps in the order shown:

1. Mounting

- Unpack your inverter from its shipping container and inspect the unit for any obvious transit damage. Report any concerns immediately to your supplier.
- Mount the inverter to a suitable surface, paying close attention to the mounting requirements previously mentioned in this manual.

2. AC Wiring

Important: to satisfy warranty requirements and conditions, a qualified electrician must perform all AC wiring.

3. DC Wiring

IT IS ESSENTIAL that the battery bank voltage matched the DC input voltage rating of the inverter. Damage to the inverter could result from improper voltage connections.

A battery fuse must be installed between the batteries and the inverter; appropriately sized Motor-starting fuses or similar are recommend.

Before making any connections ensure that the inverter circuit breaker is in the OFF position. Connect the inverter DC input cables to the battery terminal, the BLACK cable to the negative battery terminal.

4. Ground Fault Circuit Interrupters (GFCI'S)

Installations in Recreational Vehicles (for North American approval) will require GFCI protection of all branch circuits connected to the AC output of the Inverter. In addition, electrical codes require GFCI protection of certain receptacles in residential installations. While the output of the Inverter is equivalent to the waveform provided by utilities, compliance with UL standards requires us to test and recommend specific GFCI's. State power has tested the following GFCI-protected 15A receptacles and found that they functioned properly when connected to the output of the Inverter.

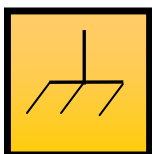

WARNING!

Do not operate the power inverter without connecting it to ground. Electrical shock hazard may result.

5. Making DC Wiring Connections:

Follow this procedure to connect the battery cables to the DC input terminals on the inverter. Your cables should be as short as possible (ideally, less than 10 feet / 3 meters) and large enough to handle the required current, in accordance with the electrical codes or regulations applicable to your installation. Cables that are not an adequate gauge (too narrow) or are too long will cause decreased inverter performance such as poor surge capability, frequent low input voltage warnings and shutdowns.

J. Connection and Testing:

For a quick connection and performance check, please follow these guidelines:

1. Unpack and inspect the power inverter, check to see that the power switch in the OFF position.
2. Connect the DC POSITIVE cable to the Positive (POS+) terminal on the battery. Next, connect the cable to the positive terminal on the inverter.
The connection to the negative (NEG-) terminal of the Inverter should be the last connection made. A spark when making this final connection is normal.



WARNING!

Make sure all the DC connections are tight (torque to 9-10 ft-lbs, 11.7-13Nm). Loose connections will overheat and could result in a **fire** hazard.

3. Before proceeding further, carefully check that cable you have just connected the positive terminal of inverter to the positive terminal of the power source.



CAUTION!

Reversed polarity connections will blow a fuse in inverter and may permanently damage the inverter.

Damage caused by a reverse polarity connection is not covered by our warranty.

4. Connect the cable securely from the negative terminal of inverter to the negative terminal of the power source.



WARNING!

You may observe a spark when you make this connection. Do not make this connection in the presence of flammable fumes.

Explosion or fire may result.

5. Set the power switch to the ON position. Check the power and RUN / GREEN POWER LED indicators on the front panel of the inverter source. If the LED is not lit, check your power source and the connections to inverter. The other indicators should be off.
6. Set power inverter switch to the OFF position. The indicator lights may blink and the internal alarm may sound momentarily. This is normal. Plug the test load into the AC receptacle on the front panel of the inverter. Leave the test load switch off.
7. Set power inverter switch to the ON position and turn the test load on. The inverter should supply power to the load. If you plan to measure the output voltage of the inverter, a meter such as FLUKE 45, BECKMAN or other Digital Volt meter must be used.

K. Operation:

To operate the power inverter, turn it on using the ON/OFF switch on the front panel. The power inverter is now ready to deliver AC power to your loads. If you are operating several loads from the power inverter, turn them on separately after the inverter has been turned on. This will ensure that the power inverter does not have to deliver the starting currents for all the loads at once.

1. Controls and indicators:

The ON/OFF switch turns the control circuit in the power inverter on and off. It does not disconnect power from the power inverter.

The Inverter operates from an input voltage ranging from:

10 to 16 VDC for 12V models

20 to 32 VDC for 24V models

42 to 62 VDC for 48V models (By custom design only)

Peak performance for the inverter occurs when DC input voltage is in the Range of 10 volts to 16 volts for 12V models and 20 volts to 32 volts for 24V models, and 42 volts to 62 volts for 48V models, from 150Watts up to 3000Watts.

2. Over voltage indicator:

The over voltage indicator indicates that the power inverter has shut itself Down because its input voltage higher than the detect voltage (12V / 24V / 48VDC versions).

3. Under voltage indicator:

The under voltage indicator indicates that the power inverter has shut itself down because its input voltage has been lower than detect voltage (12V / 24V / 48VDC versions).

4. Over temp indicator:

The over temp indicator indicates that the power inverter has shut down because it has become overheated. The power inverter may overheat because it has been operated at power levels above its rating, or because it has been installed in a location which does not allow it to dissipate heat properly. The power inverter will restart automatically once it has cooled off.

5. Overload indicator:

The overload indicator indicates that the power inverter has shut itself down because its output circuit has been short circuited or drastically overloaded. Switch the ON/OFF switch to OFF, correct the fault condition, and then switch the ON/OFF switch back to ON.

L. Green Power Adjustment:

Our inverter features automatic load-sensing, which allows the inverter to wait in Standby mode until an AC load is switched ON. When an AC load appears the inverter will immediately start. This feature conserves valuable battery energy as the inverter uses only about 10% of normal power when in standby mode (standby is indicated by flashing green lamp). The amount of AC power required to start the inverter can be adjusted, following the procedure below. Ensure battery voltage is at nominal, i.e. 12V or 24 V as appropriate for your inverter.

Adjust load sensitivity for green power mode as follows:

- Turn OFF all AC loads, keeping the AC wiring connected. Some loads such as TVs must be turned OFF at the power point as they can still represent a small load to the inverter.
- Using a small screwdriver adjust the black plastic trim pot located to the right of the two lamps below the power point. Turning this control fully clockwise will override the standby circuit and keep the inverter ON all the time: this could be used if you have a very small load that must stay ON at all times.
- Adjust the pot until the lamp is steady green, then turn the pot back a little until the lamp flashes green. Allow 10 seconds between adjustments for stabilization: clockwise is less sensitive; counter-clockwise is increased sensitivity.
- **Note:** the trim pot is extremely sensitive.
- When the lamp flashes GREEN, the unit is in standby mode.
- Turn on the smallest AC load attached to the inverter. The inverter should now deliver 240VAC, and AC status lamp should be GREEN, However, if the lamp is ORANGE the sensitivity must be increased by turning the control pot a little counter-clockwise.
- Now turn OFF the AC load. The lamp should return to flashing GREEN, indicating that the inverter is on standby. If this does not occur, reduce sensitivity by turning the control pot a little clockwise and check again.

M. Trouble Shooting:

AC output does not stay ON. Some AC loads may not large enough to hold the inverter ON. This condition is indicated by the inverter turning off after every eight to ten seconds, then back on again. The AC Status lamp will also be flashing orange.

There are two possible solutions:

Increase the sensitivity of the inverter by turning the Standby control **slightly** counter-clockwise until the lamp shows steady green;

Increase the amount of AC load on the inverter.

Inverter shuts down due to Over Temperature Your inverter will safely provide the output power defined in the technical data section under the conditions specified. If the inverter shuts down and indicates over temperature, it may be that you have exceeded one of the parameters.

Check the following:

Ensure the inverter has adequate ventilation. Insufficient ventilation can severely restrict the power output of your inverter.

Ensure that the true power rating of your appliance (including power factor) is less than the output rating of your inverter.

Inverter shuts down when trying to start a load A sudden surge in load, such as a motor starting, may cause the inverter to shut down. If this occurs;

Ensure the battery voltage is within specifications when the device is trying to start: if the voltage falls too far, you may need to increase the size of your batteries.

If the battery voltage is ok then the inverter power output may be too small.

Common problems:

1. Television interference

Operation of the power inverter can interfere with television reception on some channels. If this situation occurs, the following steps may help to alleviate the problem:

- Make sure that the chassis ground lug on the back of the power inverter is solidly connected to the ground system of your vehicle, boat or home.
- Do not operate high power loads with the power inverter while watching television.
- Make sure that the antenna feeding your television provides an adequate ("Snow free") signal and that you are using good quality cable between the antenna and the television.
- Move the television as far away from the power inverter as possible.
- Keep the cables between the battery and the power inverter as short as possible and twist them together with about 2 to 3 twists per foot. This minimizes radiated interference from the cables.



WARNING!

Do not open or disassemble inverter. Attempting to service the unit yourself may result in a risk of electrical shock or fire.

2. Troubleshooting guide:

Problem and Symptoms	Possible Cause	Solution
Low output voltage: 110V : 95-105VAC, 220V : 190-210VAC	Using average reading Voltmeter	Use true RMS and cable. See page 7, Point 6-7 of manual
Load LED flashes.	Overload	Reduce load. Remove Load.
Under Volt LED flash.	Low input voltage.	Recharge battery, check connections and cable.
Over Temp. flash.	Thermal shutdown	Improve ventilation

N. Maintenance:

Very little maintenance is required to keep your inverter operating properly. You should clean the exterior of the unit periodically with a damp cloth to prevent accumulation of dust and dirt. At the same time, tighten the screws on the DC input terminals.

O. Specifications

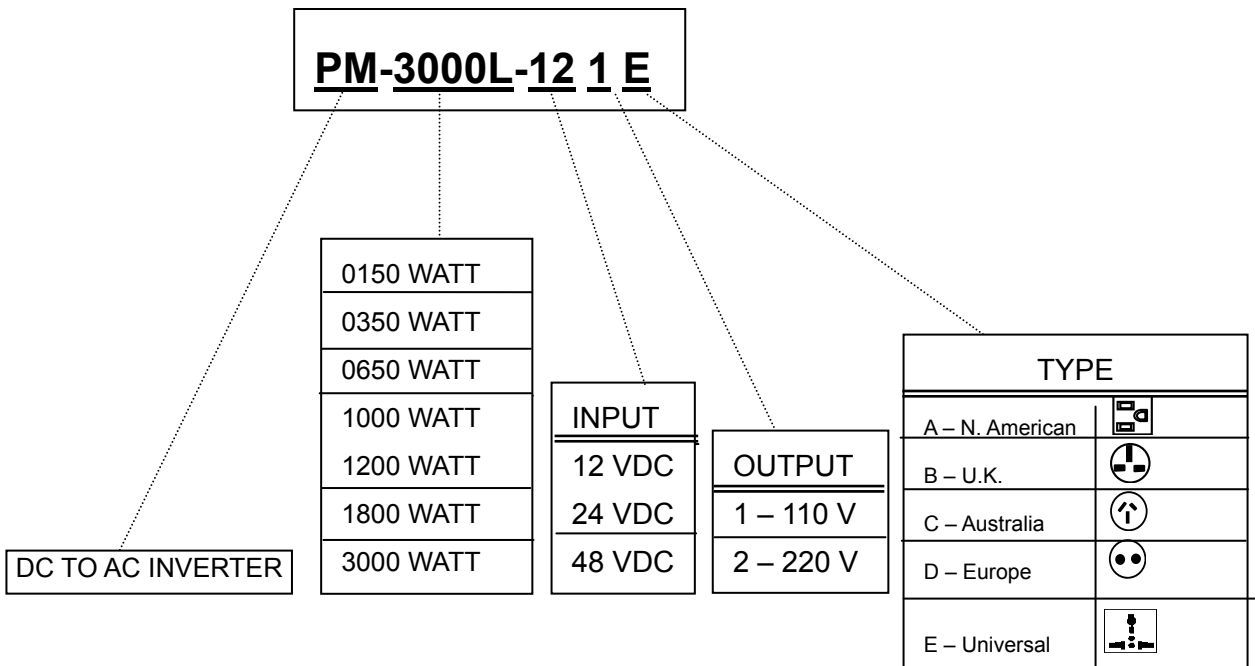

Pure Sine Wave Inverter

Model No.	PM-0150L	PM-0350L	PM-0650L	PM-1000L	PM-1200L	PM-1800L	PM-3000L
Continuous Output Power	150w	350w	650w	1000w	1200w	1800w	3000w
Output Power Surge	450w	1050w	1950w	3000w	3600w	5400w	9000w
AC Output Voltage	100 ~ 120v $\pm 5\%$ 200 ~ 240v $\pm 5\%$ adjustable		100 ~ 120v $\pm 1\sim 2\%$ 200 ~ 240v $\pm 1\sim 2\%$ adjustable				
Output Voltage Regulation	-5%~+5%		-1.5~+1.0% All models				
Output Frequency	50Hz / 60Hz $\pm 0.5\%$						
Output Wave Form	Pure Sine Wave < 4% THD		Pure Sine Wave < 2% THD				
Efficiency (Full Load)	>80%						
No Load Power Consumption	<5W		<4w (In green power status)				
Input Voltage Range	10~16 VDC / 20~32 VDC / 42~62 VDC						
Green Power Recovery Time	N/A		1 Second				
LED Status Indication	RUN, trip. LED All in one	Power ON/ OFF, RUN / STAND BY, High / Low Battery Shutdown, Over Temperature, Shutdown, and Over Load Shutdown					
Protection Feature	Input High/Low Voltage, Over Temp. and Reverse Input Polarity (Fuse). Over Load, Short Circuit Shutdown, Restarts, Soft Start						
Remote Control	N/A		ON / Off Switching with 3M or 15M wire				
Operation Temperature Range	0~50°C (32°~ 122°F)						
Storage Temperature Range	-30°C ~ 70°C (-22°C~58°F)						
Dimensions (L x W x H) mm	220*130*90	240*280*115	350*283*115	350*283*115	450*280*115	383*280*182	543*280*182
N.W. – 12V (kg)	2.6	5.8	9.1	10.6	15.8	17.4	26.4
G.W. – 12V (kg)	5.2	9.4	12.5	13.5	20.5	24.5	33.2
N.W. – 24V (kg)	2.6	5.8	9.1	10.6	16.5	16.7	23.8
G.W. – 24V (kg)	5.2	9.4	12.5	13.5	23.5	23.3	29.2